

# BASIC ANTENNA'S AND HOW THEY WORK. A BRIEF OVERVIEW

## ANTENNAS

The purpose of an antenna is to receive and/or transmit electromagnetic radiation. When the antenna is not connected directly to the transceiver, we need a transmission line (feed line) to transfer the received or transmitted signal.

I will mostly be talking about transmission. Keep in mind though; whatever is said about transmission is true of reception.

In a perfect transmitting system the transmission line would transfer all of the power from the transmitter to the antenna without any losses. The antenna should then radiate all of the power it receives as electromagnetic radiation.

We have discussed the mechanism by which an electromagnetic wave is radiated by an antenna. If you have forgotten this, refer back to the reading on electromagnetic radiation.

This reading will be targeting what you need to know for examination purposes (plus a bit more). The problem with most antenna books is that they often explain how to build antennas but not how they work.

## THE HALF WAVE DIPOLE

If you take a basic balanced transmission line such as 300 ohm TV ribbon, split it and pull it apart, you will form a dipole antenna (refer to figure 1). Each side of the half wave dipole will be 1/4 wavelength ( $\lambda/4$  or  $1/4 \lambda$ ). We learnt earlier that the free space wavelength of an electromagnetic wave is found from:

$$\lambda = 300 / f \text{ (MHz) meters.}$$

This comes from:

$$\lambda = c / f \text{ (Hz) where 'c' = 300,000,000.}$$

The constant in this equation is 'c', the velocity of light (or any other electromagnetic wave) in free space. **The velocity of a wave along an antenna (or transmission line) is slower than that in free space. In fact, for most antennas the velocity is 95% of 'c'.**

## A dipole is a 'split' transmission line

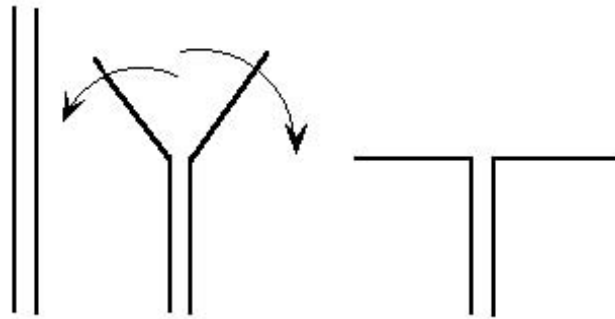

**300  $\Omega$  Ribbon (or any other)**

Figure 1.

A half wave dipole is physically 5% shorter than the freespace wavelength, because the velocity of propagation of the wave along each arm (leg) of the dipole is 5% slower than 'c'.

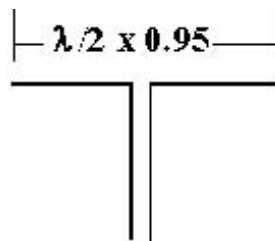

Figure 2.

**Example:** If we wanted to make a halfwave dipole for 28 MHz then:

Dipole length in meters =  $300/28 \times 0.95 \times 0.5 = 5.09$  meters.

We calculated the freespace wavelength with  $300/28$ , took 5% off it by multiplying by 0.95, then found a half wavelength by multiplying by 0.5. I strongly recommend you do not simply memorize the equations for antennas as some textbooks provide, but rather understand the calculations.

## CURRENT AND VOLTAGE DISTRIBUTION ON A HALF WAVE ANTENNA (DIPOLE)

When the wave leaves the transmission line and enters a halfwave antenna, electromagnetic radiation is created. By the way, **any antenna which is a multiple (any multiple) of a 1/4 of the physical wavelength is a resonant antenna**, you will see why shortly.

Currents and voltages will occur along the length of a dipole antenna. What the actual values of current and voltage are we don't care. We do care about the ratio of voltage to current at different points along the dipole.

Why? Do you remember earlier we talked about 'impedance' not actually being a physical thing? Any E/I ratio is in fact impedance. If we were to actually measure the current flowing in a dipole antenna, we would have to move an RF ammeter along the dipole and record the current at the centre, move out a bit and record the current again, and so on many times until we got to the end of the antenna.

If we did this we would be able to plot the current and voltage distribution of a dipole antenna. Figure 3 shows what we would get:

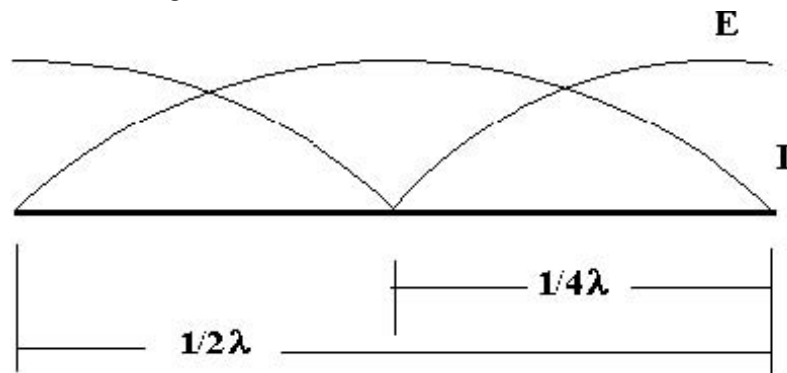

**Current and voltage distribution on an antenna**

Figure 3.

**This is a very important diagram.** It is a halfwave dipole, but has many other uses as well, so we must learn what this diagram means.

**The voltage distribution is labeled 'E' and the current 'I'.** What sort of voltage current ratio do we have at the centre of the dipole? Well, current is high and voltage is low. If I told you that I had a high current for a low voltage anywhere, what could you tell me about the impedance? The impedance must be low, as that's what a low impedance is, namely lots of current with little voltage. So the impedance at the centre of a halfwave dipole is low. In fact, impedance is lowest at the centre.

Look at the ends of the dipole. Voltage (E) is high and current (I) is low. This must mean that the ends of a dipole have a high impedance, as that's what a high impedance is, a lot of 'E' for only a little bit of 'I'.

Why can we say that the halfwave dipole antenna is resonant? Simply because it is the correct physical length to accommodate the complete halfwave of current and voltage distribution.

Let's look at this idea of resonance from a different perspective. On the dipole antenna in figure 3, the length of the antenna is long enough to fit in a full halfwave of current and voltage distribution. A full halfwave is simply two quarter waves.

**At the centre of the antenna the current and voltage represent a low (72 ohms) and RESISTIVE impedance. At the ends of the antenna the current and voltage represent a high (2000-3000 ohms) and RESISTIVE impedance.** So at the ends and the centre of the antenna the impedance is predictable and resistive. In theory, the centre is zero ohms and the ends infinite ohms.

**Anywhere between the centre and either end the impedance of the dipole antenna increases and becomes a combination of resistance and reactance.**

You also know now what the current and voltage distribution on a  $\lambda/4$  antenna is, it's just half of the distribution shown on the antenna in figure 3 above. That is, from the centre to one end.

We can say that a quarter wave antenna is resonant simply because it is the correct physical length to accommodate a complete quarter wave of current and voltage distribution. At either end of a quarter wave the impedance is resistive only. Being resistive implies resonance. With antennas, like tuned circuits, being resistive is synonymous with being resonant. Any antenna which is  $\lambda/4$  or a multiple of  $\lambda/4$  is a resonant antenna.

Why are we concerned so much about impedance? Well, we have learnt that for a load to dissipate (or radiate in the case of an antenna) all of the power it **MUST BE RESISTIVE**, and the resistance **MUST MATCH the source resistance**. In the case of an antenna system the source is usually, though not always, the end of the transmission line. For a halfwave dipole we know (irrespective of what frequency it operates on) that the feedpoint impedance at its centre is **72 ohms and resistive**, provided the antenna is resonant (the right length). So ideally we should feed a dipole with 72 ohm transmission line, and if we don't we need to do an impedance transformation, say from 50 to 72 ohms using a transformer (balun).

In practice the actual feedpoint impedance, radiation pattern, and many other properties of a dipole or any other antenna, are affected by the environment. Factors to consider include the height above ground, the proximity to metal roofs, objects, other antennas, and the like.

## PHYSICAL AND ELECTRICAL LENGTH

Because the velocity of propagation of a wave along an antenna is slower than through free space, the electrical and physical antenna lengths are not the same. The examiner has been known to test for this understanding.

The physical length of an antenna is the material length in meters you would measure with the aid of a measuring tape.

The electrical length is not a physical measurement. It is the wavelength or fraction thereof, to which an antenna is resonant. The electrical wavelength is typically 5% longer than the actual physical length of the antenna.

## ISOTROPIC ANTENNA

An isotropic antenna is a theoretical antenna only. An isotropic antenna is one which radiates equally in all directions.

The isotropic antenna is used as a mathematical model in order to evaluate the directional properties of practical antennas. Just about all antennas have a gain greater than an isotropic.

A dipole (which is usually presumed to be halfwave) has a gain of 2.14 dB above an isotropic. Hence a dipole antenna is said to have a gain of 2.14 dBi, ie. dB relative to an isotropic. Electrically very short rubber helical antennas, often referred to as a 'rubber duck', have a loss of several dB when compared to an isotropic. Such a lossy antenna would be described as having a gain of say  $-n$  dBi. Negative gain really means attenuation below an isotropic.

Some antenna manufactures will use the isotropic antenna as their reference point when quoting antenna gains, others will use the dipole as the reference. The purchaser should

be aware which reference is used when gain figures are quoted, as there is a 2.14 dB difference between the two reference levels.

## ANTENNA GAIN

Most radio communications are point to point or at least confined to an area. An antenna which directs most of its energy toward the receiving station can be said to have a power advantage over an omnidirectional antenna. The power gain of a transmitting antenna is the ratio of the power radiated in its maximum direction of radiation compared to that radiated by a standard antenna, usually a dipole or the theoretical isotropic.

Suppose amateur stations (A) and (B) are in contact with station (C). Station (A) is using a dipole antenna and (B) a Yagi with a gain of 6 dB above a dipole.

How much would station (A) need to increase his transmitter power to overcome the antenna gain advantage of station (B)?

Station (A) would need to increase his transmitter power by 6dB or, in other words, quadruple it.

As a matter of interest, a transmitter power increase by a factor of four or an antenna gain of 6 dB, should increase the received signal by one 'S' point. That is, provided the S-meter is correctly calibrated.

There are many traps when attempting to evaluate antenna performance on air, as in the latter example. Sometimes a dipole antenna will out-perform an antenna with higher gain because it has a more favorable angle of radiation for the propagation conditions in existence at the time of the comparison. Improved communications when using a directional antenna may at times be due to enhanced received signals and reduction in noise at the receiver, rather than transmit power gain.

## RADIATION RESISTANCE

Radiation resistance is an imaginary resistance which, when put in place of an antenna, dissipates as much power as the antenna radiates.

The higher the radiation resistance the more efficient the antenna is as a radiator. With some antennas (eg. a dipole or a quarter wave antenna) the feedpoint impedance and the radiation resistance are the same. If the feedpoint impedance of an antenna were to be changed by some impedance conversion device, this would not alter the radiation resistance.

## LOSS RESISTANCE

Loss resistance is an imaginary resistance that represents the power losses of the antenna to the ground or other nearby conductors.

## FEEDPOINT IMPEDANCE

Feedpoint Impedance is that impedance seen by the feedline and is determined by the standing wave ratio (VSWR) at the feedpoint (to be discussed).

## MORE ON RESONANCE AND RESISTANCE

Any tuned circuit is resonant when both the inductive and capacitive reactances are equal.

At resonance the reactances completely cancel, leaving only the resistive part of the impedance. The shortest length of wire that can be resonant without any artificial loading is a quarter wavelength. A quarter wavelength of wire will have zero net reactance and a resistive feedpoint impedance of about 36 ohms (half of the dipole).

If an antenna is less than a quarter wave, it will appear capacitive and will require the addition of some inductance, known as a loading coil. The added inductance cancels out the capacitive reactance and resonates the antenna.

An antenna which is longer than a quarter wave but less than a half wave will have a net inductive reactance and will require the addition of some capacitive loading to resonate it.

## FIVE-EIGHTH WAVELENGTH

One popular antenna is the  $5/8\lambda$  vertical (figure 4). Now a  $5/8\lambda$  antenna cannot be resonant since it is not a multiple of a quarter wave. The whip part of the antenna is in fact  $5/8$ th of a wavelength and has a net capacitive reactance. All  $5/8\lambda$  antennas have an inductance (loading coil) fitted somewhere along the length of the antenna to cancel out the capacitive reactance and resonate the antenna. The  $5/8\lambda$  antenna is tuned by the loading coil to resonate as a  $3/4\lambda$  antenna. So in effect, a  $5/8\lambda$  antenna is electrically really a  $3/4\lambda$ .

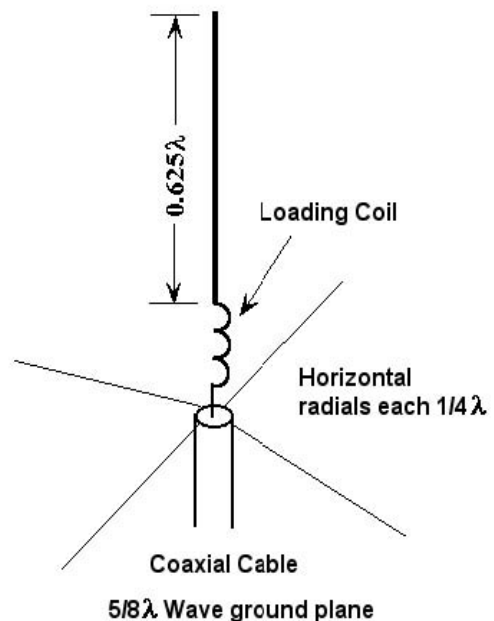

## THE QUARTER WAVE ANTENNA

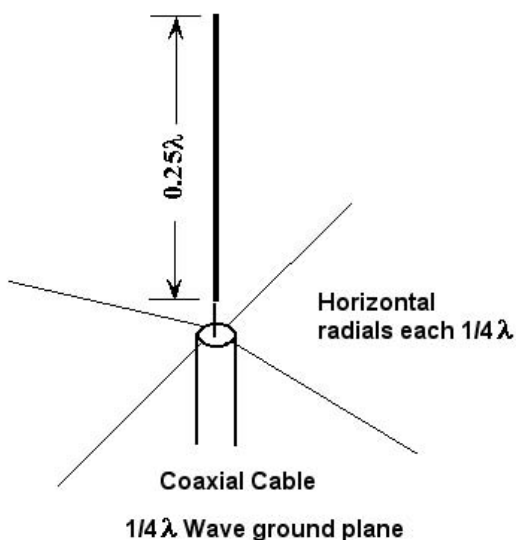

Figure 5.

A quarter wave antenna (figure 5) is normally used with radials or installed on a flat conducting ground plane, such as the roof of a car or house, or just a good conducting ground.

A ground plane is simply a reflector. Some of the radiation from the antenna will be reflected by the ground plane and this reflected wave will interact with the incident wave from the antenna in such a way as to modify the radiation pattern of the antenna. In the case of a quarter wave antenna, the 'ground' should be as uniform as possible around the antenna so as to provide an omnidirectional pattern.

Where it is not possible to mount the antenna on a conducting surface such as the earth or a car body, the ground plane effect can be simulated by attaching at least three quarter wave length radials to the feedpoint on the earth side of the feeder. Radials have another advantage, in that by lowering them to an angle of about 45 degrees to the horizontal, the feed point impedance can be raised from 36 to 50 ohms to provide a closer match to a 50 ohm coaxial cable.

I have seen it asked in exams why the radials of a ground plane antenna are drooped downwards at 45 degrees. One of the amusing answers, which I have often seen ticked as correct is, "to prevent birds from standing on them"! -Wrong.

## ANTENNA LOADING

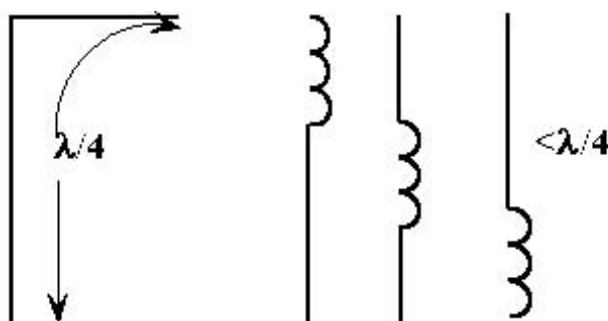

Figure 6.

Loading, as discussed earlier, is adding inductance or capacitance to an antenna in order to make it resonant.

Top loading is a name given to various methods of adding capacitance or inductance to the top of the physically short antenna. Top loading not only adds the desired reactance to resonate the antenna, but shifts the current distribution pattern higher up the antenna, increasing the radiation resistance and hence the radiation efficiency. What I am saying is that top loading is preferable to bottom or even centre loading. However for mechanical reasons, particularly with mobile antennas, bottom loading is often used. The higher the loading coil the better. An alternative is to distribute the inductance along the length of the antenna, perhaps even winding turns closer as you approach the top. This can be done on a fiberglass rod and the whole antenna coated with paint or sealant, or heat shrink tubing can be used. This is the method used for so called helical mobile antennas.

On the low HF bands, the length of a grounded quarter wave can become impractical. An antenna that is physically short will not be resonant and its input impedance has a high capacitive reactance. Consequently antenna current decreases and radiation decreases.

The radiation resistance decreases from 36 ohms for a quarter wave antenna towards zero as the length is reduced. Because of the short length, the current maximum will not occur on the antenna, but on the transmission line. The loss of the high current peak on the antenna drastically reduces the radiator power. Adding a loading coil at the base of a short vertical would resonate the antenna and increase the radiation resistance by about five ohms. However, the current loop would still be low on the antenna and high  $I^2R$  losses in the coil would reduce the radiation efficiency.

These difficulties are overcome by using top loading. A cylinder, sphere or disc placed at the top of the antenna acts to increase the **shunt capacitance to ground** which, in effect, is

the same as adding inductance in series with the antenna, thereby bringing the antenna to resonance. The current distribution on the antenna is "pulled up" higher on the antenna resulting in higher radiation resistance and radiation efficiency. There is no real significance in the shape of the metallic top loading device. The shapes mentioned earlier are normally used for the ease of capacitance calculation and appearance sake. A piece of wire can be used for top loading making the antenna appear as an inverted "L" or a "T".

## YAGI

The parasitic beam, or Yagi array (named after Dr. Hidetsugu Yagi of Tokyo University), was invented in 1926 and was first used in the amateur service about 1935.

A Yagi antenna must have one driven element, a dipole, and at least one other parasitic element (refer to figure 7). In our earlier discussion of a dipole, I mentioned that the radiation pattern, input impedance, and many other characteristics, are determined by the height above ground and nearby antennas, among other things.

Well, a Yagi is just a dipole with other parasitic dipoles nearby (on the same boom). The parasitic dipoles receive radiation from the dipole and then re-radiate. So, we have energy being radiated from the main driven element and then after a time delay, energy picked up and re-radiated by the parasitic elements. By controlling the spacing and length of the parasitic elements, the antenna array can be made to have a main lobe in one direction, providing substantial gain.

## THREE ELEMENT YAGI

This antenna has three elements: driven element, reflector, and director. The main lobe of radiation used is in the direction of driven element to director. The physical length of the driven element is found by the same equation as that given for a dipole. The reflector is 5% longer than the driven element and the director 5% shorter. The spacing between the elements can vary from 0.15 to 0.2 wavelengths. Maximum forward gain is obtained at a spacing of 0.18 wavelengths.

The director and reflector are called parasitic elements as they intercept energy radiated from the driven element and then re-radiate it. When the parasitic elements absorb power they re-radiate it with a wave pattern like that of a dipole. However, because of the propagation delays introduced by the spacing of the elements, wave cancellation occurs toward the rear of the antenna and wave reinforcement in the forward direction. This wave reinforcement results in a gain of about 6-8.5 dB over a dipole. The feedpoint impedance is about 18-25  $\Omega$ . Some type of matching device is required to convert the feed point impedance to 50  $\Omega$  if coaxial cable is used.

Additional parasitic elements can be added to a 3 element Yagi to increase the power gain further. Additional elements are always directors, placed in front of the driven element. Adding more reflectors provides no appreciable gain advantage at HF frequencies. Doubling the number of directors will increase the power gain by approximately 3dB. Adding parasitic elements to a Yagi array decreases the antenna bandwidth.

The front-to-back ratio of a three element Yagi varies from about 15 dB to a maximum of 25 dB. The front-to-back ratio is the ratio of the power radiated in the forward direction to that radiated to the rear of the antenna, expressed in decibels.

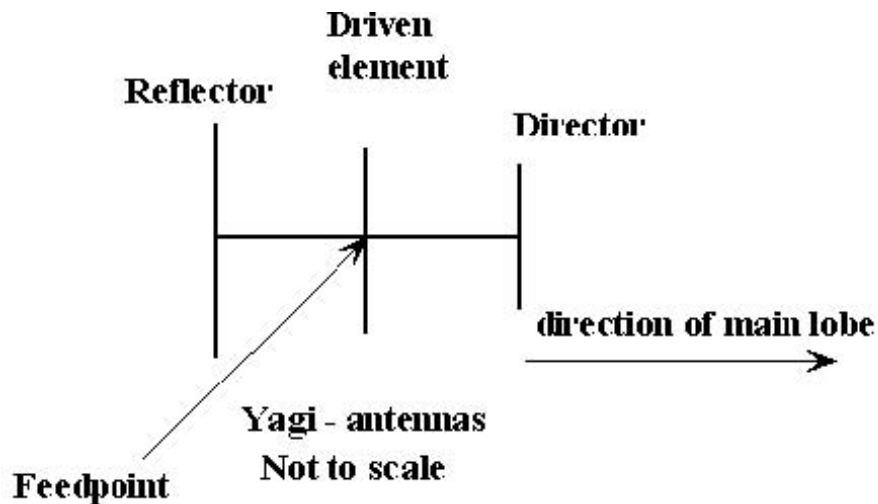

Figure 7.

Each element of a Yagi antenna has a current and voltage distribution like that of a simple dipole. As the impedance at the centre of each element is the same, and no current will flow between points of equal impedance on an antenna, a metallic boom may be used.

If two identical Yagi antennas are stacked in phase and the gain of each individual Yagi is 6 dB, the stacked array will have a total gain of 9 dB, that is, 3 dB more.

The additional second antenna would theoretically double the amount of power radiated in the forward direction. This is an effective power increase of 3 dB, giving a total system gain of 9 dB. In practice, the additional gain would be slightly less than the theoretical maximum. Stacking a third antenna would result in an improvement of an additional 33% or 1.24 dB at best.

## FOLDED DIPOLE

A folded dipole antenna (refer to figure 8) can best be described as two dipoles connected in parallel. Folding a dipole has the effect of increasing the feed point impedance. With two parallel dipoles the feedpoint impedance is increased by a factor of  $2^2 = 4$ , giving a total impedance of 300 ohms for a standard dipole. With three parallel dipoles the feed point impedance becomes  $2^3 = 8$  times the original feed point impedance. The dipole forming the driven element of a Yagi antenna is often folded to increase the feed point impedance by a factor of 4.

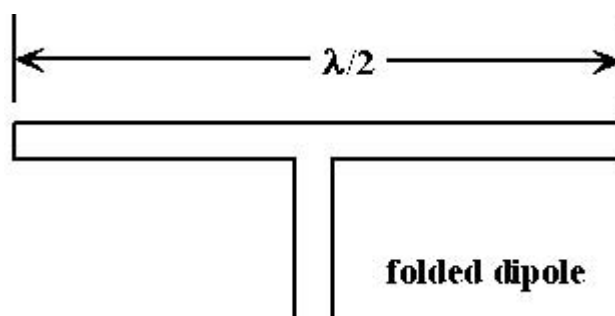

Figure 8.

## SINGLE QUAD LOOP ANTENNA

A quad antenna is really a "pulled out" folded dipole. Just imagine pulling out a folded dipole to form a square or diamond. A folded dipole has a radiation resistance of  $288 \Omega$  ( $4 \times 72$ ). When half pulled out to form a quad loop, the antenna is half way between being a folded dipole and a shorted transmission line (see next reading). A shorted half wavelength of transmission line would have an input impedance of zero ohms one half wavelength back from the termination. It is not surprising that the feedpoint impedance of a single quad loop is the mean (average) of these two values:  $(288 + 0) / 2 = 144$  ohms. When fed at the centre of one side, the impedance decreases slightly to 125 ohms.

With this antenna there is no "end" to the wire elements as the quad forms a continuous loop. The shortening effect which occurs with other antennas is not applicable since there is no "end effect". In fact, for a quad loop to be resonant, it actually has to be slightly longer than a quarter wave on each side.

Summarizing the important characteristics of a quad loop:

Radiation resistance is  $144 \Omega$  when fed at a corner.

Radiation resistance is  $125 \Omega$  when fed at the centre of one side.

Power gain is 1.4 dB above a dipole.

Bi-directional radiation pattern.

The physical length of each side is  $0.257 \lambda$ .

## BASIC RADIATION PATTERNS

In the unrestricted exam you are expected to be able to identify the very basic radiation patterns.

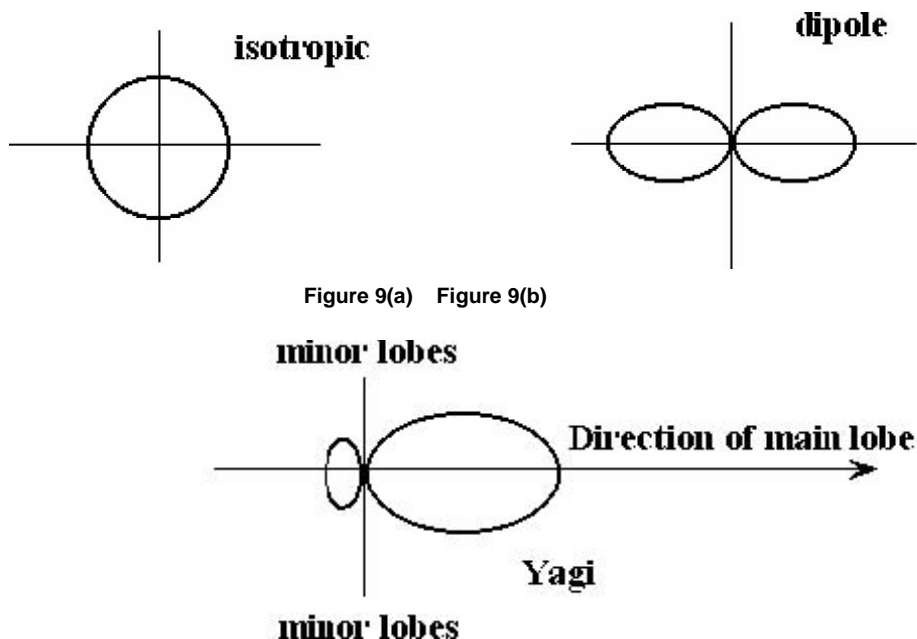

Figure 9(a) Figure 9(b)

Figure 9(c)

The dipole is a bi-directional antenna, but you could identify this pattern as that of a single quad loop as well. The pattern of a Yagi would have many small minor lobes which I have not shown, however this is how it is shown in the exam.

## TRAPPED DIPOLES AND VERTICALS

Traps used on HF antennas are parallel tuned circuits. Recall that at resonance, a parallel tuned circuit has very high impedance. The higher its "Q" the higher the impedance. In fact if the "Q" was high enough, a parallel tuned circuit impedance could be likened to an **open circuit switch**.

Trapped antennas use the high impedance of a parallel tuned circuit to switch in and out different sections of the antenna. Have a look at the three band trapped dipole of figure 10.

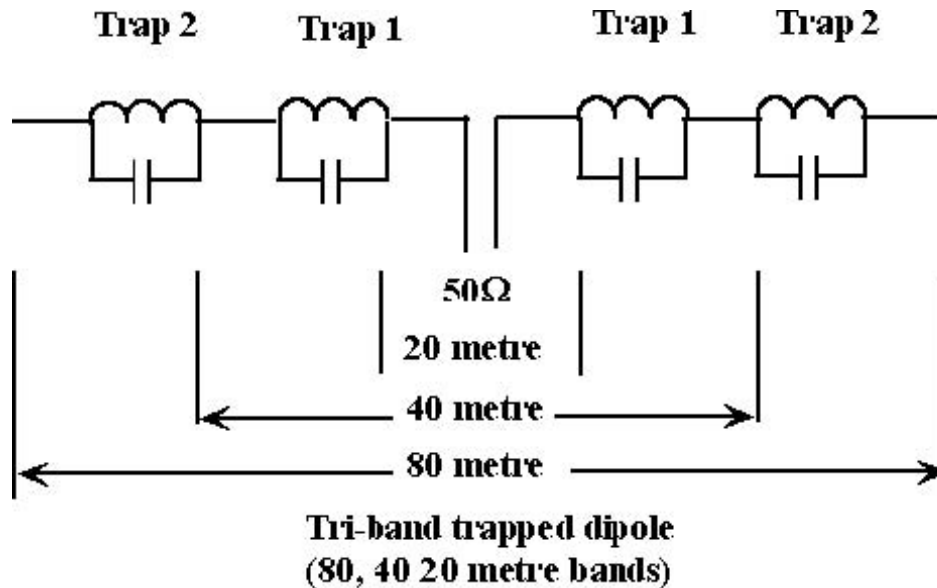

Figure 10.

The highest frequency band is 20 meters. The Trap1's will be parallel resonant on a 20 meters frequency and the transmitter will only "see" the smaller antenna in the centre. On 40 meters the Trap1's are no longer resonant. The 40 meter band is the middle section of the antenna shown. The Trap2's are parallel resonant on 40 meters, isolating the ends of the antenna. On the 80 meters band (the lowest frequency) the whole antenna is used. When the traps are not used on their resonant frequencies they act like loading coils and effectively shorten the length of antenna wire needed.

Half of this antenna could be stood up vertically and you would have a trapped vertical. You can even make a trapped multiband Yagi using this same principle for the driven element, directors and the reflector.

The traps may be made from an actual high "Q" inductor and capacitor, however there are easier methods on HF. On VHF and above the options for traps and other matching techniques becomes enormous.