

High-Performance Yagis for 144, 222 and 432 MHz

This construction information is presented as an introduction to the three high-performance VHF/UHF Yagis that follow. All were designed and built by Steve Powlishen, K1FO. For years the design of long Yagi antennas seemed to be a mystical black art. The problem of simultaneously optimizing 20 or more element spacings and element lengths presented an almost unsolvable set of simultaneous equations. With the unprecedented increase in computer power and widespread availability of antenna analysis software, we are now able to quickly examine many Yagi designs and determine which approaches work and which designs to avoid.

At 144 MHz and above, most operators desire Yagi antennas two or more wavelengths in length. This length (2λ) is where most classical designs start to fall apart in terms of gain per boom length, bandwidth and pattern quality. Extensive computer and antenna range analysis has proven that the best possible design is a Yagi that has

both varying element spacings and varying element lengths.

This design approach starts with closely spaced directors. The director spacings gradually increase until a constant spacing of about 0.4λ is reached. Conversely, the director lengths start out longest with the first director and decrease in length in a decreasing rate of change until they are virtually constant in length. This method of construction results in a wide gain bandwidth. A bandwidth of 7% of the center frequency at the -1 dB forward-gain points is typical for these Yagis even when they are longer than 10λ . The log-taper design also reduces the rate of change in driven-element impedance vs frequency. This allows the use of simple dipole driven elements while still obtaining acceptable driven-element SWR over a wide frequency range. Another benefit is that the resonant frequency of the Yagi changes very little as the boom length is increased.

The driven-element impedance also changes moderately with boom length. The tapered approach creates a Yagi with a very clean radiation pattern. Typically, first side lobe levels of ~ 17 dB in the E plane, ~ 15 dB in the H plane, and all other lobes at ~ 20 dB or more are possible on designs from 2λ to more than 14λ .

The actual rate of change in element lengths is determined by the diameter of the elements (in wavelengths). The spacings can be optimized for an individual boom length or chosen as a best compromise for most boom lengths.

The gain of long Yagis has been the subject of much debate. Recent measurements and computer analysis by both amateurs and professionals indicates that given an optimum design, doubling a Yagi's boom length will result in a maximum theoretical gain increase of about 2.6 dB. In practice, the real gain increase may be less because of escalating resistive losses and the greater possibility of construction error. **Fig 37** shows the maximum possible gain per boom length expressed in decibels, referenced to an isotropic radiator. The actual number of directors does not play an important part in determining the gain vs boom length as long as a reasonable number of directors are used. The use of more directors per boom length will normally give a wider gain bandwidth, however, a point exists where too many directors will adversely affect all performance aspects.

While short antennas ($< 1.5 \lambda$) may show increased gain with the use of quad or loop elements, long Yagis ($> 2 \lambda$) will not exhibit measurably greater forward gain or pattern integrity with loop-type elements. Similarly, loops used as driven elements and reflectors will not significantly change the properties of a long log-taper Yagi. Multiple-dipole driven-element assemblies will also not result in any significant gain increase per given boom length when compared to single-dipole feeds.

Once a long-Yagi director string is properly tuned, the reflector becomes relatively non critical. Reflector spacings between 0.15λ and 0.2λ are preferred. The spacing can be chosen for best pattern and driven element impedance. Multiple-reflector arrangements will not significantly increase the forward gain of a Yagi which has its directors properly optimized for forward gain. Many multiple-reflector schemes such as tri-reflectors and corner reflectors have the disadvantage of lowering the driven element impedance compared to a single optimum-length reflector. The plane or grid reflector, shown in **Fig 38**, may however reduce the intensity of unwanted rear lobes. This can be used to reduce noise pickup on EME or satellite arrays. This type of reflector will usually increase the driven-element impedance compared to a single reflector. This sometimes makes driven-element matching easier. Keep in mind that even for EME, a plane reflector will add considerable wind load and weight for

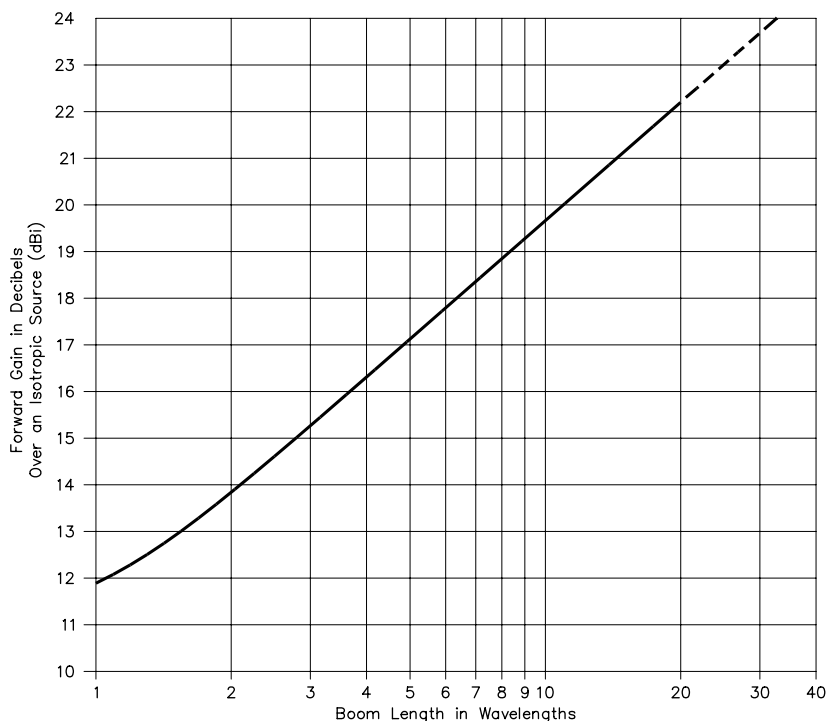

Fig 37—This chart shows maximum gain per boom length for optimally designed long Yagi antennas.

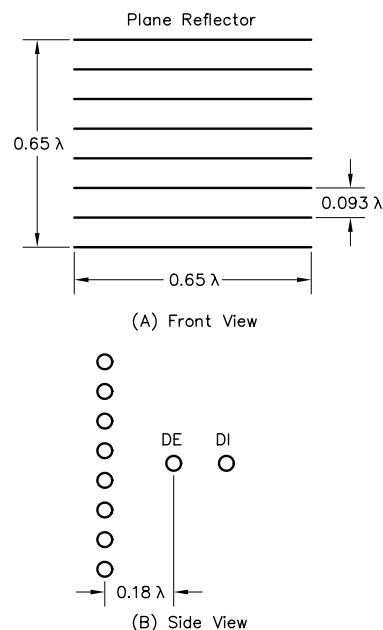

Fig 38—Front and side views of a plane-reflector antenna.

only a few tenths of a decibel of receive signal-to-noise improvement.

Yagi Construction

Normally, aluminum tubing or rod is used for Yagi elements. Hard-drawn enamel-covered copper wire can also be used on Yagis above 420 MHz. Resistive losses are inversely proportional to the square of the element diameter and the square root of its conductivity.

Element diameters of less than $\frac{3}{16}$ inch or 4 mm should not be used on any band. The size should be chosen for reasonable strength. Half-inch diameter is suitable for 50 MHz, $\frac{3}{16}$ to $\frac{3}{8}$ inch for 144 MHz and $\frac{3}{16}$ inch is recommended for the higher bands. Steel, including stainless steel and unprotected brass or copper wire, should not be used for elements.

Boom material may be aluminum tubing, either square or round. High-strength aluminum alloys such as 6061-T6 or 6063-T651 offer the best strength-to-weight advantages. Fiberglass poles have been used (where available as surplus). Wood is a popular low-cost boom material. The wood should be well seasoned and free from knots. Clear pine, spruce and Douglas fir are often used. The wood should be well treated to avoid water absorption and warping.

Elements may be mounted insulated or uninsulated, above or through the boom. Mounting uninsulated elements through a metal boom is the least desirable method unless the elements are welded in place. The Yagi elements will oscillate, even in moderate winds. Over several years this element oscillation will work open the boom holes. This will allow the elements to move in the boom. This will create noise (in your receiver) when the wind blows, as the element contact changes. Eventually the element-to-boom junction will corrode (aluminum oxide is a good insulator). This loss of electrical contact between the boom and element will reduce the boom's effect and change the resonant frequency of the Yagi.

Noninsulated elements mounted above the boom will perform fine as long as a good mechanical connection is made. Insulating blocks mounted above the boom will also work, but they require additional fabrication. One of the most popular construction methods is to mount the elements through the boom using insulating shoulder washers. This method is lightweight and durable. Its main disadvantage is difficult disassembly, making this method of limited use for portable arrays.

If a conductive boom is used, element lengths must be corrected for the mounting method used. The amount of correction is dependent upon the boom diameter in

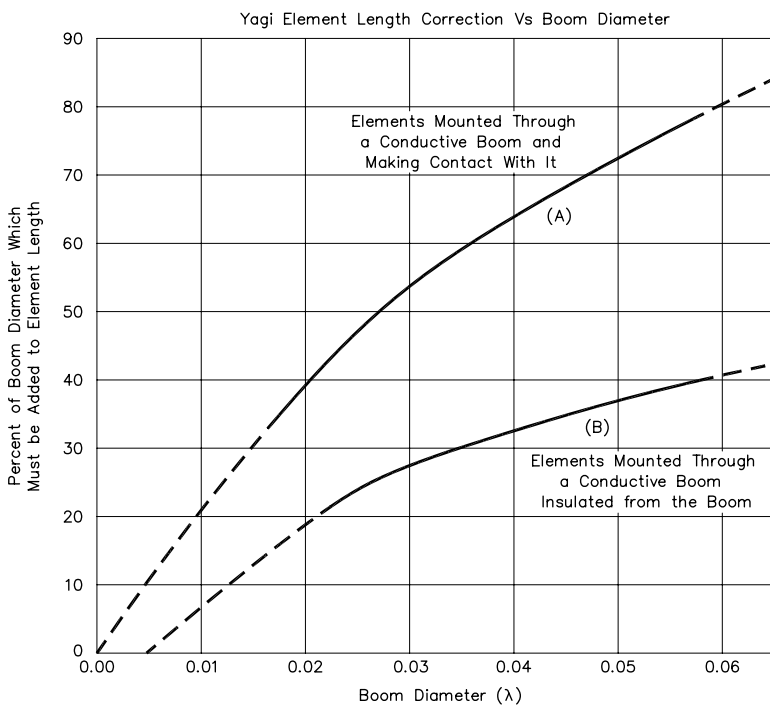

Fig 39—Yagi element correction vs boom diameter. Curve A is for elements mounted through a round or square conductive boom, with the elements in mechanical contact with the boom. Curve B is for insulated elements mounted through a conductive boom, and for elements mounted on top of a conductive boom (elements make electrical contact with the boom). The patterns were corrected to computer simulations to determine Yagi tuning. The amount of element correction is not affected by element diameter.

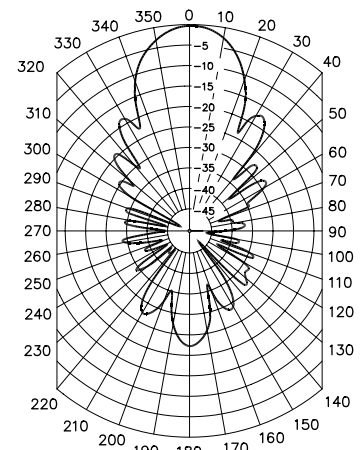

Fig 40—Measured E-plane pattern for the 22-element Yagi. Note: This antenna pattern is drawn on a linear dB grid, rather than on the standard ARRL log-periodic grid, to emphasize low sidelobes.

wavelengths. See **Fig 39**. Elements mounted through the boom and not insulated require the greatest correction. Mounting on top of the boom or through the boom on insulated shoulder washers requires about half of the through-the-boom correction. Insulated elements mounted at least one element diameter above the boom require no correction over the free-space length.

The three following antennas have been optimized for typical boom lengths on each band.

A HIGH-PERFORMANCE 432-MHz YAGI

This 22-element, 6.1- λ , 432-MHz Yagi was originally designed for use in a 12-Yagi EME array built by K1FO. A lengthy evaluation and development process preceded its construction. Many designs were considered and then analyzed on the computer. Next, test models were constructed and evaluated on a home-made antenna range. The resulting design is based on WIEJ's computer-optimized spacings.

The attention paid to the design process has been worth the effort. The 22-element Yagi not only has exceptional forward gain (17.9 dBi), but has an unusually clean radiation pattern. The measured E-plane pattern is

shown in **Fig 40**. Note that a 1-dB-per-division axis is used to show pattern detail. A complete description of the design process and construction methods appears in December 1987 and January 1988 *QST*.

Like other log-taper Yagi designs, this one can easily be adapted to other boom lengths. Versions of this Yagi have been built by many amateurs. Boom lengths ranged between 5.3 λ (20 elements) and 12.2 λ (37 elements).

The size of the original Yagi (169 inches long, 6.1 λ) was chosen so the antenna could be built from small-diameter boom material ($7/8$ -inch and 1 inch round 6061-T6 aluminum) and still survive high winds and ice loading. The 22-element Yagi weighs about 3.5 pounds and has a wind load of approximately 0.8 square feet. This allows a high-gain EME array to be built with manageable wind load and weight. This same low wind load and weight lets the tropo operator add a high-performance 432-MHz array to an existing tower without sacrificing antennas on other bands.

Table 7 lists the gain and stacking specifications for the various length Yagis. The basic Yagi dimensions are shown in **Table 8**. These are free-space element lengths for $3/16$ -inch-diameter elements. Boom corrections for the element mounting method must be added in. The element-length correction column gives the length that must be added to keep the Yagi's center frequency optimized for use at 432 MHz. This correction is required to use the same spacing pattern over a wide range of boom lengths. Although any length Yagi will work well, this design is at its best when made with 18 elements or more (4.6 λ). Element material of less than $3/16$ -inch diameter is not recommended because resistive losses will reduce the gain by about 0.1 dB, and wet-weather performance will be worse.

Quarter-inch-diameter elements could be used if all elements are shortened by 3 mm. The element lengths are intended for use with a slight chamfer (0.5 mm) cut into the element ends. The gain peak of the array is centered at 437 MHz. This allows acceptable wet-weather performance, while reducing the gain at 432 MHz by only 0.05 dB.

The gain bandwidth of the 22-element Yagi is 31 MHz (at the -1 dB points). The SWR of the Yagi is less than 1.4:1 between 420 and 440 MHz. **Fig 41** is a network analyzer plot of the driven-element SWR vs frequency. These numbers indicate just how wide the frequency response of a log-taper Yagi can be, even with a simple dipole driven element. In fact, at one antenna gain contest, some ATV operators conducted gain vs frequency measurements from 420 to 440 MHz. The 22-element Yagi beat all entrants including those with so-called broadband feeds.

To peak the Yagi for use on 435 MHz (for satellite use), you may want to shorten all the elements by 2 mm. To peak it for use on 438 MHz (for ATV applications), shorten all elements by 4 mm. If you want to use the Yagi

Table 7
Specifications for 432-MHz Yagi Family

No. of Ele.	Boom length(λ)	Gain (dBi)*	F/B ratio (dB)	DE imped (Ω)	Beamwidth E/H ($^\circ$)	Stacking E/H (inches)
15	3.4	15.67	21	23	30/32	53/49
16	3.8	16.05	19	23	29/31	55/51
17	4.2	16.45	20	27	28/30	56/53
18	4.6	16.8	25	32	27/29	58/55
19	4.9	17.1	25	30	26/28	61/57
20	5.3	17.4	21	24	25.5/27	62/59
21	5.7	17.65	20	22	25/26.5	63/60
22	6.1	17.9	22	25	24/26	65/62
23	6.5	18.15	27	30	23.5/25	67/64
24	6.9	18.35	29	29	23/24	69/66
25	7.3	18.55	23	25	22.5/23.5	71/68
26	7.7	18.8	22	22	22/23	73/70
27	8.1	19.0	22	21	21.5/22.5	75/72
28	8.5	19.20	25	25	21/22	77/75
29	8.9	19.4	25	25	20.5/21.5	79/77
30	9.3	19.55	26	27	20/21	80/78
31	9.7	19.7	24	25	19.6/20.5	81/79
32	10.2	19.8	23	22	19.3/20	2/80
33	10.6	9.9	23	23	19/19.5	83/81
34	11.0	20.05	25	22	18.8/19.2	84/82
35	11.4	20.2	27	25	18.5/19.0	85/83
36	11.8	20.3	27	26	18.3/18.8	86/84
37	12.2	20.4	26	26	18.1/18.6	87/85
38	12.7	20.5	25	25	18.9/18.4	88/86
39	13.1	20.6	25	23	18.7/18.2	89/87
40	13.5	20.8	26	21	17.5/18	90/88

*Gain is approximate real gain based on gain measurements made on six different-length Yagis.

Table 8
Free-Space Dimensions for 432-MHz Yagi Family

*Element correction is the amount to shorten or lengthen all elements when building a Yagi of that length. Element lengths are for $\frac{3}{16}$ -inch diameter material.

Ele. No.	Element Position (mm from reflector)	Element Length (mm)	Element Correction*
Refl	0	340	
DE	104	334	
D1	146	315	
D2	224	306	
D3	332	299	
D4	466	295	
D5	622	291	
D6	798	289	
D7	990	287	
D8	1196	285	
D9	1414	283	
D10	1642	281	-2
D11	1879	279	-2
D12	2122	278	-2
D13	2373	277	-2
D14	2629	276	-2
D15	2890	275	-1
D16	3154	274	-1
D17	3422	273	-1
D18	3693	272	0
D19	3967	271	0
D20	4242	270	0
D21	4520	269	0
D22	4798	269	0
D23	5079	268	0
D24	5360	268	+1
D25	5642	267	+1
D26	5925	267	+1
D27	6209	266	+1
D28	6494	266	+1
D29	6779	265	+2
D30	7064	265	+2
D31	7350	264	+2
D32	7636	264	+2
D33	7922	263	+2
D34	8209	263	+2
D35	8496	262	+2
D36	8783	262	+2
D37	9070	261	+3
D38	9359	261	+3

on FM between 440 MHz and 450 MHz, shorten all the elements by 10 mm. This will provide 17.6 dBi gain at 440 MHz, and 18.0 dBi gain at 450 MHz. The driven element may have to be adjusted if the element lengths are shortened.

Although this Yagi design is relatively broadband, it is suggested that close attention be paid to copying the design exactly as built. Metric dimensions are used because they are convenient for a Yagi sized for 432 MHz.

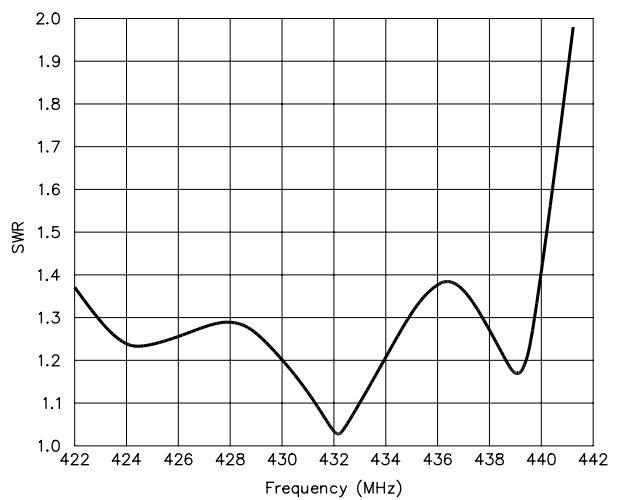

Fig 41—SWR performance of the 22-element Yagi in dry weather.

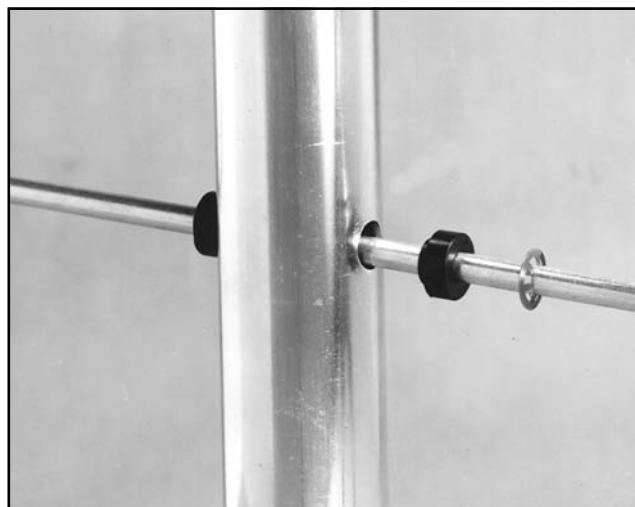

Fig 42—Element-mounting detail. Elements are mounted through the boom using plastic insulators. Stainless steel push-nut retaining rings hold the element in place.

Element holes should be drilled within ± 2 mm. Element lengths should be kept within ± 0.5 mm. Elements can be accurately constructed if they are first rough cut with a hack saw and then held in a vise and filed to the exact length.

The larger the array, the more attention you should pay to making all Yagis identical. Elements are mounted on shoulder insulators and run through the boom (see Fig 42). The element retainers are stainless-steel push nuts. These are made by several companies, including Industrial Retaining Ring Co in Irvington, New Jersey, and AuVeco in Ft Mitchell, Kentucky. Local industrial hardware distributors can usually order them for you. The element insulators

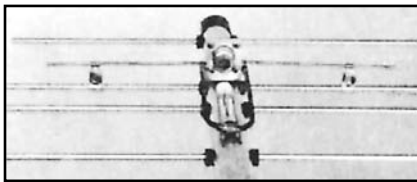
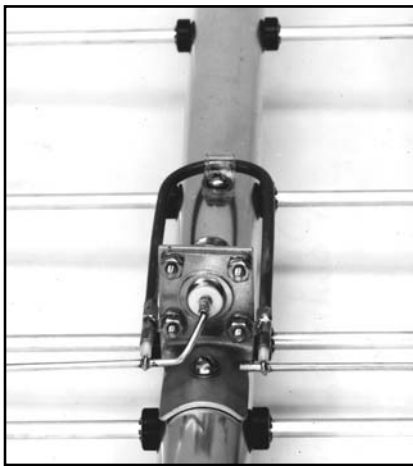
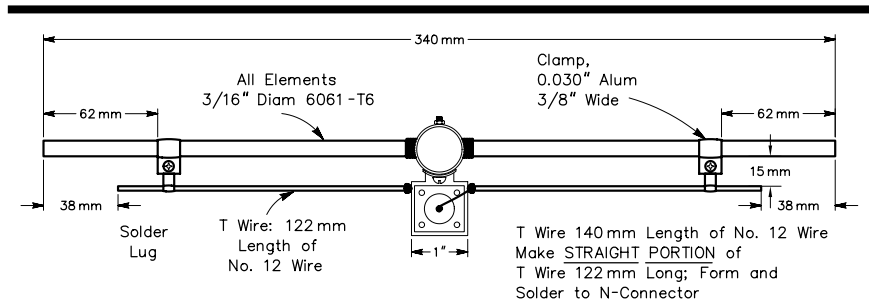
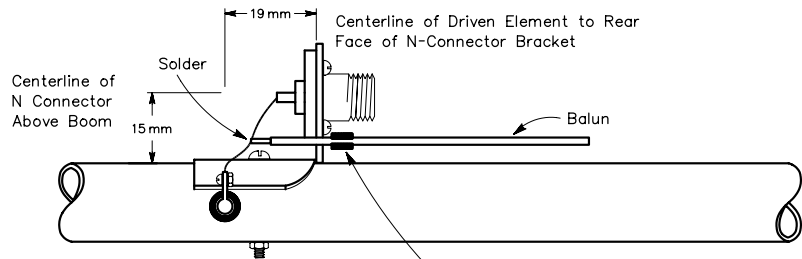
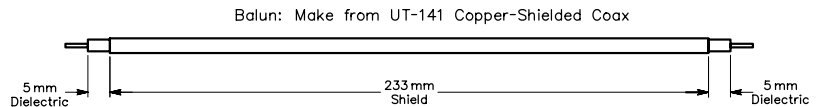

Fig 43—Several views of the driven element and T match.



Note: T Wires are Parallel to Driven Element



Solder Lug Attached to Bottom Screw on Connector, Bent 90° and Soldered to UT-141 Shield

Side View

Fig 44—Details of the driven element and T match for the 22-element Yagi. Lengths are given in millimeters to allow precise duplication of the antenna. See text.

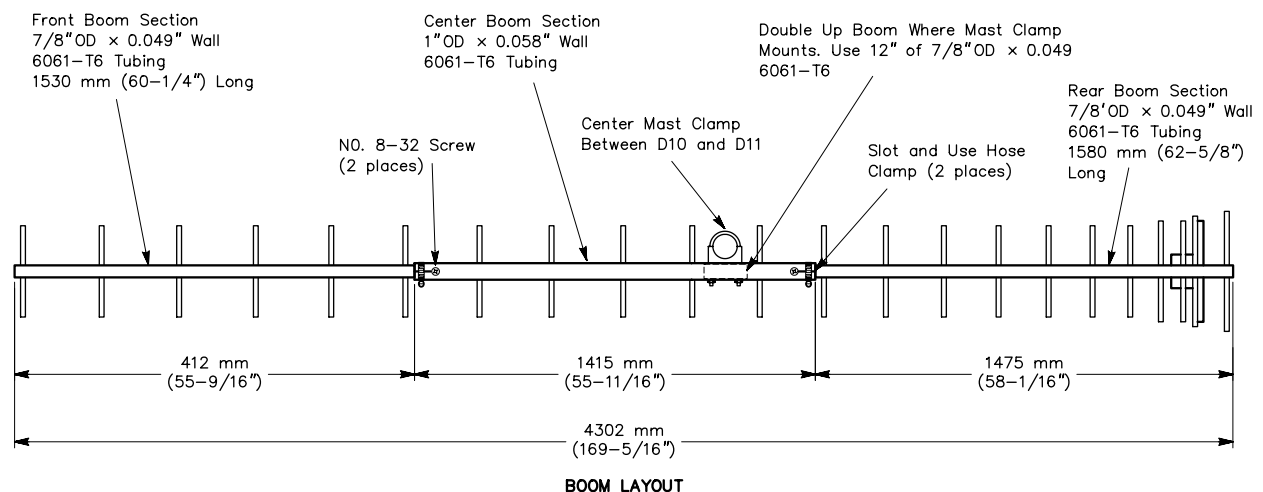

Fig 45—Boom-construction information for the 22-element Yagi. Lengths are given in millimeters to allow precise duplication of the antenna. See text.

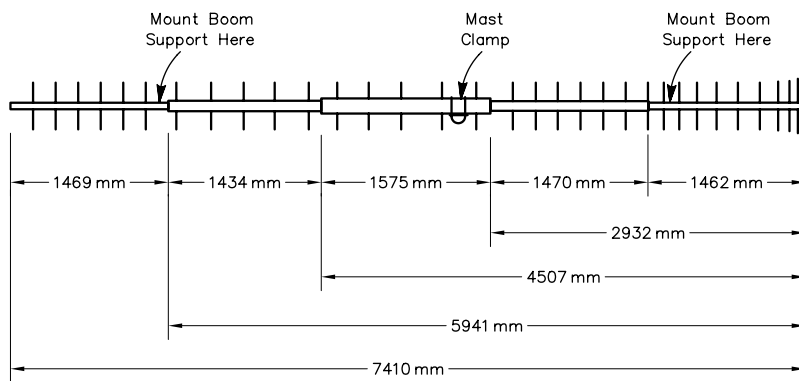

Fig 46—Boom-construction information for the 33-element Yagi. Lengths are given in millimeters to allow precise duplication of the antenna.

are not critical. Teflon or black polyethylene are probably the best materials. The Yagi in the photographs is made with black Delryn insulators, available from C3i in Washington, DC.

The driven element uses a UG-58A/U connector mounted on a small bracket. The UG58A/U should be the type with the press-in center pin. UG-58s with center pins held in by “C” clips will usually leak water. Some connectors use steel retaining clips, which will rust and leave a conductive stripe across the insulator. The T-match wires are supported by the UT-141 balun. RG-303/U or RG-142/U Teflon-insulated cable could be used if UT-141 cannot be obtained. **Fig 43A** and **Fig 42B** show details of the driven-element construction. Driven element dimensions are given in **Fig 44**.

Dimensions for the 22-element Yagi are listed in **Table 9**. **Fig 45** details the Yagi’s boom layout. Element material can be either $\frac{3}{16}$ inch 6061-T6 aluminum rod or hard aluminum welding rod.

A 24-foot-long, 10.6λ , 33-element Yagi was also built. The construction methods used were the same as the 22-element Yagi. Telescoping round boom sections of 1, $1\frac{1}{8}$, and $1\frac{1}{4}$ inches in diameter were used. A boom support is required to keep boom sag acceptable. At 432 MHz, if boom sag is much more than two or three inches, H-plane pattern distortion will occur. Greater amounts of boom sag will reduce the gain of a Yagi. **Table 10** lists the proper dimensions for the antenna when built with the previously given boom diameters. The boom layout is shown in **Fig 46**, and the driven element is described in **Fig 47**. The 33-element Yagi exhibits the same clean pattern traits as the 22-element Yagi (see **Fig 48**). Measured gain of the 33-element Yagi is 19.9 dBi at 432 MHz. A measured gain sweep of the 33-element Yagi gave a -1 dB gain bandwidth of 14 MHz with the -1 dB points at 424.5 MHz and 438.5 MHz.

A HIGH-PERFORMANCE 144MHZ YAGI

This 144MHz Yagi design uses the latest log-tapered element spacings and lengths. It offers near theoretical

gain per boom length, an extremely clean pattern and wide bandwidth. The design is based upon the spacings used in a 4.5λ 432-MHz computerdeveloped design by W1EJ. It is quite similar to the 432MHz Yagi described elsewhere in this chapter. Refer to that project for additional construction diagrams and photographs.

Mathematical models do not always directly translate into real working examples. Although the computer design provided a good starting point, the author, Steve Powlishen, K1FO, built several test models before the final working Yagi was obtained. This hands-on tuning included changing the element-taper rate in order to obtain the flexibility that allows the Yagi to be built with different boom lengths.

The design is suitable for use from 1.8λ (10 elements) to 5.1λ (19 elements). When elements are added to a Yagi, the center frequency, feed impedance and front-to-back ratio will range up and down. A modern tapered design will minimize this effect and allow the builder to select any desired boom length. This Yagi’s design capabilities per boom length are listed in **Table 11**.

The gain of any Yagi built around this design will be within 0.1 to 0.2 dB of the maximum theoretical gain at the design frequency of 144.2 MHz. The design is intentionally peaked high in frequency (calculated gain peak is about 144.7 MHz). It has been found that by doing this, the SWR bandwidth and pattern at 144.0 to 144.3 MHz will be better, the Yagi will be less affected by weather and its performance in arrays will be more predictable. This design starts to drop off in performance if built with fewer than 10 elements. At less than 2λ , more traditional designs perform well.

Table 12 gives free-space element lengths for $\frac{1}{4}$ inch-diameter elements. The use of metric notation allows for much easier dimensional changes during the design stage. Once you become familiar with the metric system, you’ll probably find that construction is easier without the burden of cumbersome English fractional units. For $\frac{3}{16}$ inch-diameter elements, lengthen all parasitic elements by 3 mm. If $\frac{3}{8}$ inch diameter elements are used, shorten all of the

Table 9

Dimensions for the 22-Element 432-MHz Yagi

Element Number	Element Position (mm from reflector)	Element Length (mm)	Boom Diam (in)
Refl	30	346	
DE	134	340	
D1	176	321	7/8
D2	254	311	
D3	362	305	
D4	496	301	
D5	652	297	
D6	828	295	
D7	1020	293	
D8	1226	291	
D9	1444	289	
D10	1672	288	
D11	1909	286	1
D12	2152	285	
D13	2403	284	
D14	2659	283	
D15	2920	281	
D16	3184	280	7/8
D17	3452	279	
D18	3723	278	
D19	3997	277	
D20	4272	276	

Table 10

Dimensions for the 33-Element 432-MHz Yagi

Element Number	Element Position (mm from reflector)	Element Length (mm)	Boom Diam (in)
REF	30	348	
DE	134	342	
D1	176	323	
D2	254	313	
D3	362	307	
D4	496	303	
D5	652	299	1
D6	828	297	
D7	1020	295	
D8	1226	293	
D9	1444	291	
D10	1672	290	
D11	1909	288	1 1/8
D12	2152	287	
D13	2403	286	
D14	2659	285	
D15	2920	284	
D16	3184	284	
D17	3452	283	1 1/4
D18	3723	282	
D19	3997	281	
D20	4272	280	
D21	4550	278	
D22	4828	278	
D23	5109	277	1 1/8
D24	5390	277	
D25	5672	276	
D26	5956	275	
D27	6239	274	
D28	6524	274	1
D29	6809	273	
D30	7094	273	
D31	7380	272	

directors and the reflector by 6 mm. The driven element will have to be adjusted for the individual Yagi if the 12-element design is not adhered to.

For the 12-element Yagi, 1/4-inch diameter elements were selected because smaller-diameter elements become rather flimsy at 2 meters. Other diameter elements can be used as described previously. The 2.5-λ boom was chosen because it has an excellent size and wind load vs gain and pattern trade-off. The size is also convenient; three 6-foot-long pieces of aluminum tubing can be used without any waste. The relatively large-diameter boom sizes (1 1/4 and 1 3/8 inches) were chosen, as they provide an extremely rugged Yagi that does not require a boom support. The 12-element 17-foot-long design has a calculated wind survival of close to 120 mph! The absence of a boom support also makes vertical polarization possible.

Longer versions could be made by telescoping smaller-size boom sections into the last section. Some sort of boom support will be required on versions longer than 22 feet. The elements are mounted on shoulder insulators and mounted through the boom. However, elements may

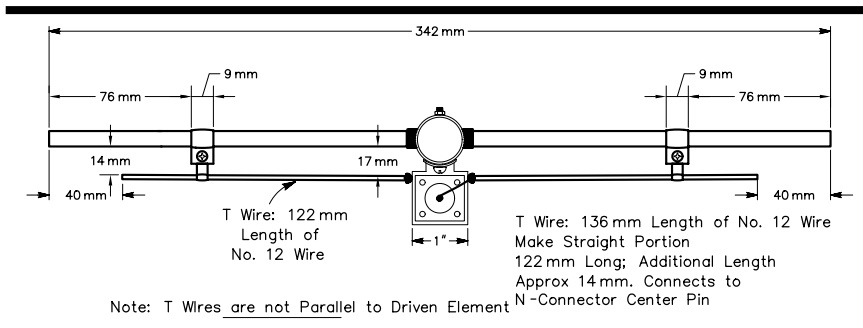

Fig 47—Details of the driven element and T match for the 33-element Yagi. Lengths are given in millimeters to allow precise duplication of the antenna.

Table 11
Specifications for the 144-MHz Yagi Family

No. of Ele.	Boom Length(λ)	Gain (dBd)	DE Imped (Ω)	FB Ratio (dB)	Beamwidth E/H ($^\circ$)	Stacking E/H ($^\circ$)
10	1.8	11.4	27	17	39/42	10.2/9.5
11	2.2	12.0	38	19	36/40	11.0/10.0
12	2.5	12.5	28	23	34/37	11.7/10.8
13	2.9	13.0	23	20	32/35	12.5/11.4
14	3.2	13.4	27	18	31/33	12.8/12.0
15	3.6	13.8	35	20	30/32	13.2/12.4
16	4.0	14.2	32	24	29/30	13.7/13.2
17	4.4	14.5	25	23	28/29	14.1/13.6
18	4.8	14.8	25	21	27/28.5	14.6/13.9
19	5.2	15.0	30	22	26/27.5	15.2/14.4

be mounted, insulated or uninsulated, above or through the boom, as long as appropriate element length corrections are made. Proper tuning can be verified by checking the depth of the nulls between the main lobe and first side lobes. The nulls should be 5 to 10 dB below the first side-lobe level at the primary operating frequency. The boom layout for the 12-element model is shown in Fig 49. The actual corrected element dimensions for the 12-element 2.5- λ Yagi are shown in Table 13.

The design may also be cut for use at 147 MHz. There is no need to change element spacings. The element lengths should be shortened by 17 mm for best operation between 146 and 148 MHz. Again, the driven element will have to be adjusted as required.

The driven-element size ($1/2$ -inch diameter) was chosen to allow easy impedance matching. Any reasonably sized driven element could be used, as long as appropriate length and T-match adjustments are made. Different

Table 12
Free-Space Dimensions for the 144-MHz Yagi Family

Element diameter is $1/4$ inch

Element No.	Element Position (mm from reflector)	Element Length
Refl.	0	1038
DE	312	955
D1	447	956
D2	699	932
D3	1050	916
D4	1482	906
D5	1986	897
D6	2553	891
D7	3168	887
D8	3831	883
D9	4527	879
D10	5259	875
D11	6015	870
D12	6786	865
D13	7566	861
D14	8352	857
D15	9144	853
D16	9942	849
D17	10744	845

driven-element dimensions are required if you change the boom length. The calculated natural driven-element impedance is given as a guideline. A balanced T-match was chosen because it's easy to adjust for best SWR and provides a balanced radiation pattern. A 4:1 half-wave coaxial balun is used, although impedance-transforming quarter-wave sleeve baluns could also be used. The cal-

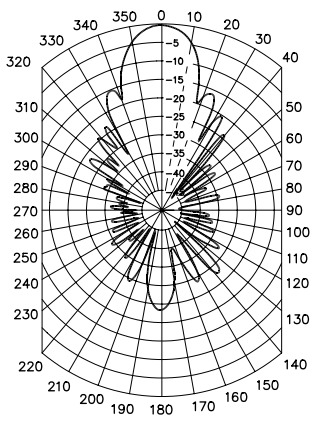

Fig 48—E-plane pattern for the 33-element Yagi. This pattern is drawn on a linear dB grid scale, rather than the standard ARRL log-periodic grid, to emphasize low sidelobes.

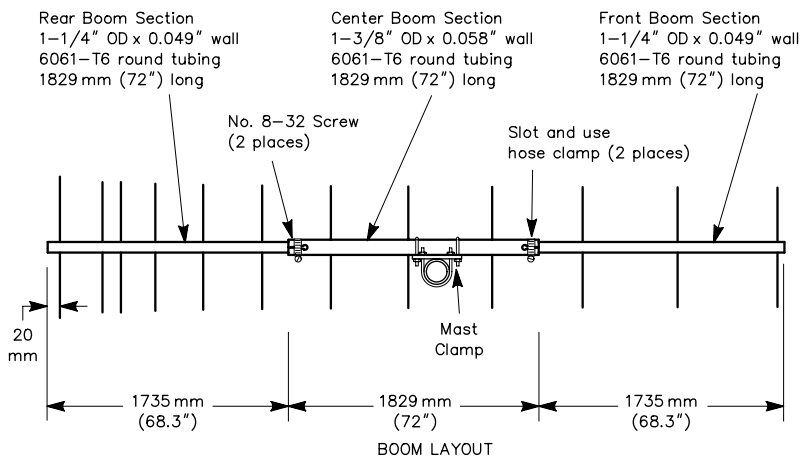
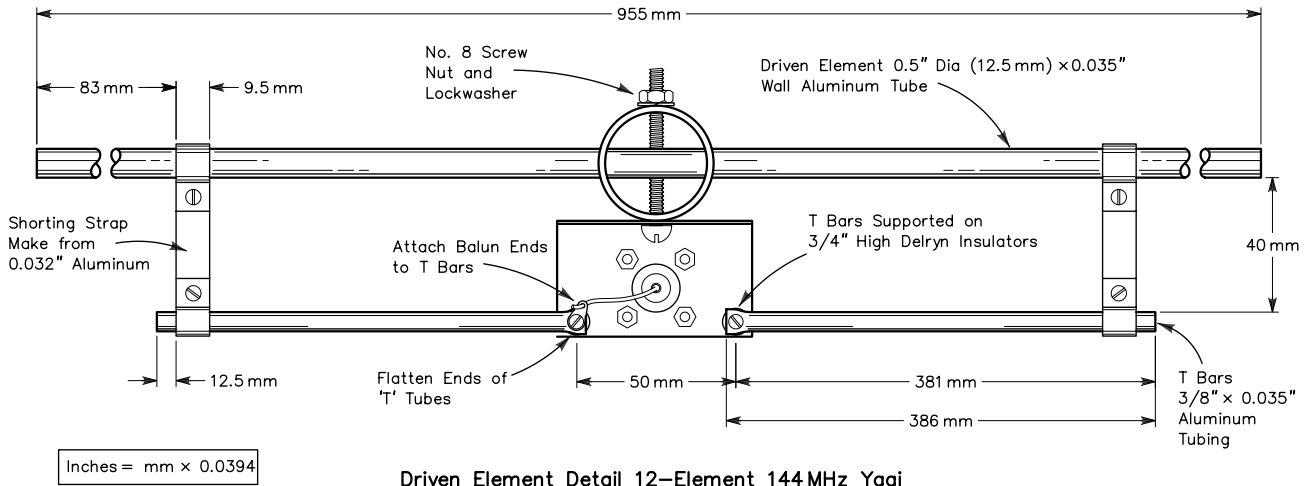
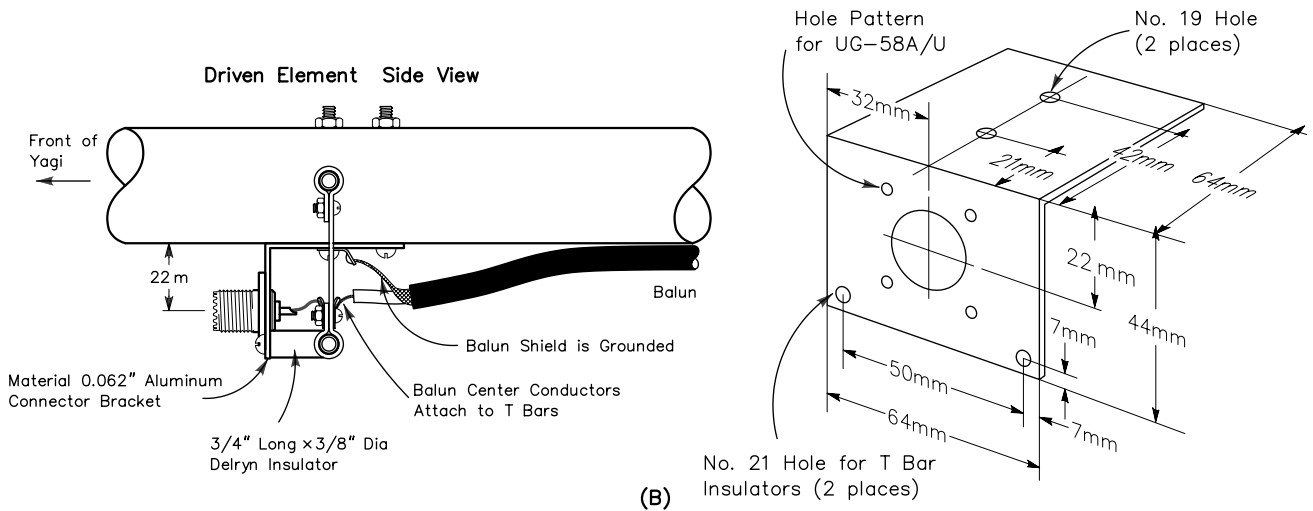

Fig 49—Boom layout for the 12-element 144-MHz Yagi. Lengths are given in millimeters to allow precise duplication.



Driven Element Detail 12-Element 144 MHz Yagi

(A)



(B)

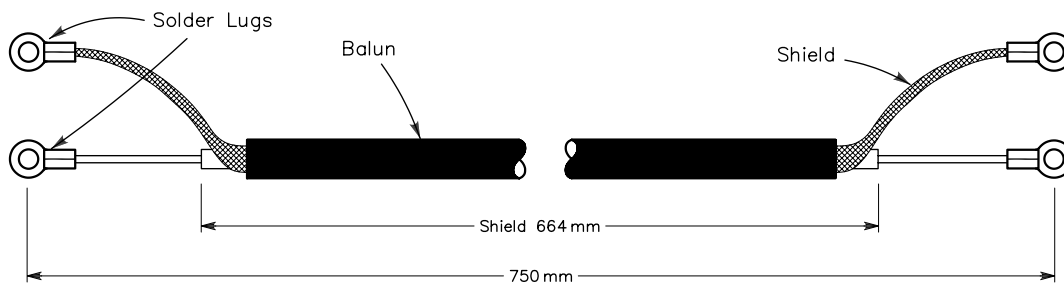

Material: RG-142/U or RG-303/U Teflon-Insulated Coaxial Cable

(C)

Ant18-50

Fig 50—Driven-element detail for the 12-element 144-MHz Yagi. Lengths are given in millimeters to allow precise duplication.

Table 13**Dimensions for the 12-Element 2.5-λ Yagi**

Element Number	Element Position (mm from reflector)	Element Length (mm)	Boom Diam (in)
Refl.	0	1044	
DE	312	955	
D1	447	962	1 ¹ / ₄
D2	699	938	
D3	1050	922	
D4	1482	912	
D5	1986	904	
D6	2553	898	1 ³ / ₈
D7	3168	894	
D8	3831	889	
D9	4527	885	1 ¹ / ₄
D10	5259	882	

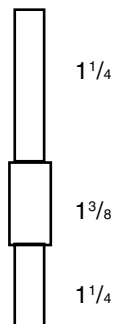
**Table 14****Free-Space Dimensions for the 222-MHz Yagi Family**

Element diameter is 3/16-inch.

Element No.	Element Position (mm from reflector)	Element Length (mm)
Refl.	0	676
DE	204	647
D1	292	623
D2	450	608
D3	668	594
D4	938	597
D5	1251	581
D6	1602	576
D7	1985	573
D8	2395	569
D9	2829	565
D10	3283	562
D11	3755	558
D12	4243	556
D13	4745	554
D14	5259	553
D15	5783	552
D16	6315	551
D17	6853	550
D18	7395	549
D19	7939	548
D20	8483	547

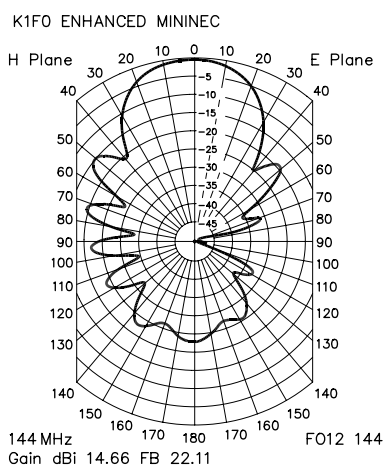
**Fig 51—H- and E-plane pattern for the 12-element 144-MHz Yagi.**

culated natural impedance will be useful in determining what impedance transformation will be required at the 200-Ω balanced feed point. Chapter 26, *Coupling the Line to the Antenna*, contains information on calculating folded-dipole and T-match driven-element parameters. A balanced feed is important for best operation on this antenna. Gamma matches can severely distort the pattern balance. Other useful driven-element arrangements are the Delta match and the folded dipole, if you're willing to sacrifice some flexibility. **Fig 50** details the driven-element dimensions.

A noninsulated driven element was chosen for mounting convenience. An insulated driven element may also be used. A grounded driven element may be less affected by static build-up. On the other hand, an insulated driven element allows the operator to easily check his feed lines for water or other contamination by the use of an ohmmeter from the shack.

Fig 51 shows computer-predicted E- and H-plane radiation patterns for the 12-element Yagi. The patterns are plotted on a 1-dB-per-division linear scale instead of the usual ARRL polar-plot graph. This expanded scale plot is used to show greater pattern detail. The pattern for the 12-element Yagi is so clean that a plot done in the standard ARRL format would be almost featureless, except for the main lobe and first sidelobes.

The excellent performance of the 12-element Yagi is demonstrated by the reception of Moon echoes from several of the larger 144MHz EME stations with only one 12-element Yagi. Four of the 12-element Yagis will make an excellent starter EME array, capable of working many EME QSOs while being relatively small in size. The advanced antenna builder can use the information in Table 11 to design a dream array of virtually any size.

A HIGH-PERFORMANCE 222-MHz YAGI

Modern tapered Yagi designs are easily applied to 222 MHz. This design uses a spacing progression that is in between the 12-element 144-MHz design, and the 22-element 432-MHz design presented elsewhere in this chapter. The result is a design with maximum gain per boom length, a clean, symmetrical radiation pattern, and wide bandwidth. Although it was designed for weak-signal work (tropospheric scatter and EME), the design is

Table 15
Specifications for the 222-MHz Yagi Family

No of Ele.	Boom Length(λ)	Gain (dBd)	FB Ratio (dB)	DE Imped (Ω)	Beamwidth E/H ($^\circ$)	Stacking E/H (feet)
12	2.4	12.3	22	23	37/39	7.1/6.7
13	2.8	12.8	19	28	33/36	7.8/7.2
14	3.1	13.2	20	34	32/34	8.1/7.6
15	3.5	13.6	24	30	30/33	8.6/7.8
16	3.9	14.0	23	23	29/31	8.9/8.3
17	4.3	14.35	20	24	28/30.5	9.3/8.5
18	4.6	14.7	20	29	27/29	9.6/8.9
19	5.0	15.0	22	33	26/28	9.9/9.3
20	5.4	15.3	24	29	25/27	10.3/9.6
21	5.8	15.55	23	24	24.5/26.5	10.5/9.8
22	6.2	15.8	21	23	24/26	10.7/10.2

suiting to all modes of 222-MHz operation, such as packet radio, FM repeater operation and control links.

The spacings were chosen as the best compromise for a 3.9- λ 16-element Yagi. The 3.9- λ design was chosen, like the 12-element 144-MHz design, because it fits perfectly on a boom made from three 6-foot-long aluminum tubing sections. The design is quite extensible, and models from 12 elements (2.4 λ) to 22 elements (6.2 λ) can be built from the dimensions given in **Table 14**. Note that free-space lengths are given. They must be corrected for the element-mounting method. Specifications for various boom lengths are shown in **Table 15**.

Construction

Large-diameter (1 $\frac{1}{4}$ - and 1 $\frac{3}{8}$ -inch diameter) boom construction is used, eliminating the need for boom supports. The Yagi can also be used vertically polarized. Three-sixteenths-inch-diameter aluminum elements are used. The exact alloy is not critical; 6061-T6 was used, but hard aluminum welding rod is also suitable. Quarter-inch-diameter elements could also be used if all elements

are shortened by 3 mm. Three-eighths-inch-diameter elements would require 10-mm shorter lengths. Elements smaller than $\frac{3}{16}$ inch-diameter are not recommended. The elements are insulated and run through the boom. Plastic shoulder washers and stainless steel retainers are used to hold the elements in place. The various pieces needed to build the Yagi may be obtained from C3i in Washington, DC. **Fig 52** details the boom layout for the 16-element Yagi. **Table 16** gives the dimensions for the 16-element Yagi as built. The driven element is fed with a T match and a 4:1 balun. See **Fig 53** for construction details. See the 432-MHz Yagi project elsewhere in this chapter for additional photographs and construction diagrams.

The Yagi has a relatively broad gain and SWR curve, as is typical of a tapered design, making it usable over a wide frequency range. The example dimensions are intended for use at 222.0 to 222.5 MHz. The 16-element Yagi is quite usable to more than 223 MHz. The best compromise for covering the entire band is to shorten all parasitic elements by 4 mm. The driven element will have to be adjusted in length for best match. The position of the T-wire shorting straps may also have to be moved.

The aluminum boom provides superior strength, is lightweight, and has a low wind-load cross section. Aluminum is doubly attractive, as it will long outlast wood and fiberglass. Using state-of-the-art designs, it is unlikely that significant performance increases will be achieved in the next few years. Therefore, it's in your best interest to build an antenna that will last many years. If suitable wood or fiberglass poles are readily available, they may be used without any performance degradation, at least when the wood is new and dry. Use the free-space element lengths given in **Table 16** for insulated-boom construction.

The pattern of the 16-element Yagi is shown in **Fig 54**. Like the 144-MHz Yagi, a 1-dB-per-division plot is used to detail the pattern accurately. This 16-element design makes a good building block for EME or tropo DX arrays. Old-style narrow-band Yagis often perform

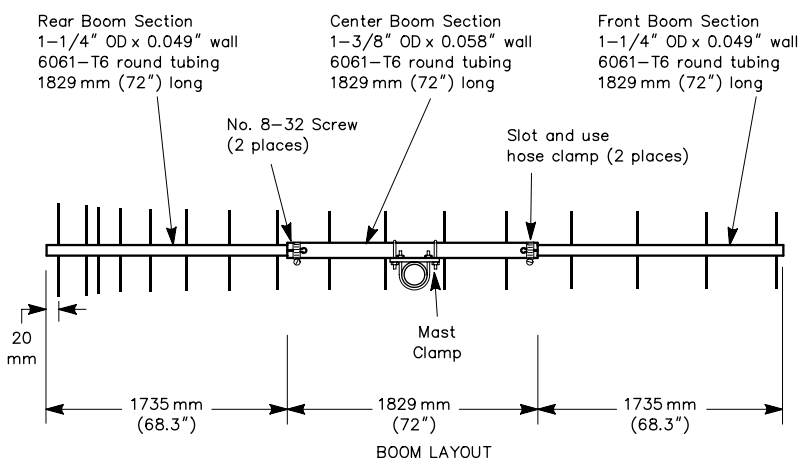

Fig 52—Boom layout for the 16-element 222-MHz Yagi. Lengths are given in millimeters to allow precise duplication.

Table 16

Dimensions for 16-Element 3.9-λ 222-MHz Yagi

Element Number	Element Position (mm from reflector)	Element Length (mm)	Boom Diam (in)
Refl.	0	683	
DE	204	664	
D1	292	630	
D2	450	615	
D3	668	601	
D4	938	594	
D5	1251	588	
D6	1602	583	
D7	1985	580	
D8	2395	576	
D9	2829	572	
D10	3283	569	
D11	3755	565	
D12	4243	563	
D13	4745	561	
D14	5259	560	

unpredictably when used in arrays. The theoretical 3.0-dB stacking gain is rarely observed. The 16-element Yagi (and other versions of the design) reliably provides stacking gains of nearly 3 dB. (The spacing dimensions listed in Table 15 show just over 2.9 dB stacking gain.) This has been found to be the best compromise between gain, pattern integrity and array size. Any phasing line losses will subtract from the possible stacking gain. Mechanical misalignment will also degrade the performance of an array.

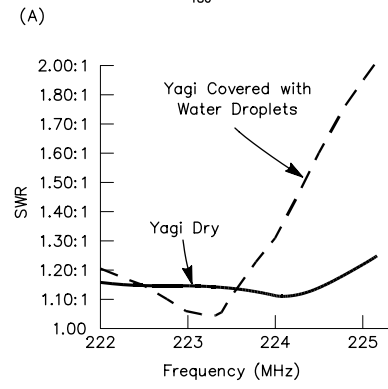
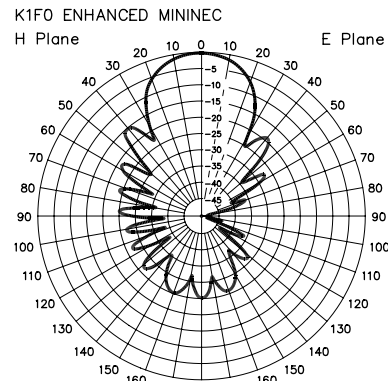

Fig 54—H- and E-plane patterns for the 16-element 222-MHz Yagi at A. The driven-element T-match dimensions were chosen for the best SWR compromise between wet and dry weather conditions. The SWR vs frequency curve shown at B demonstrates the broad frequency response of the Yagi design.

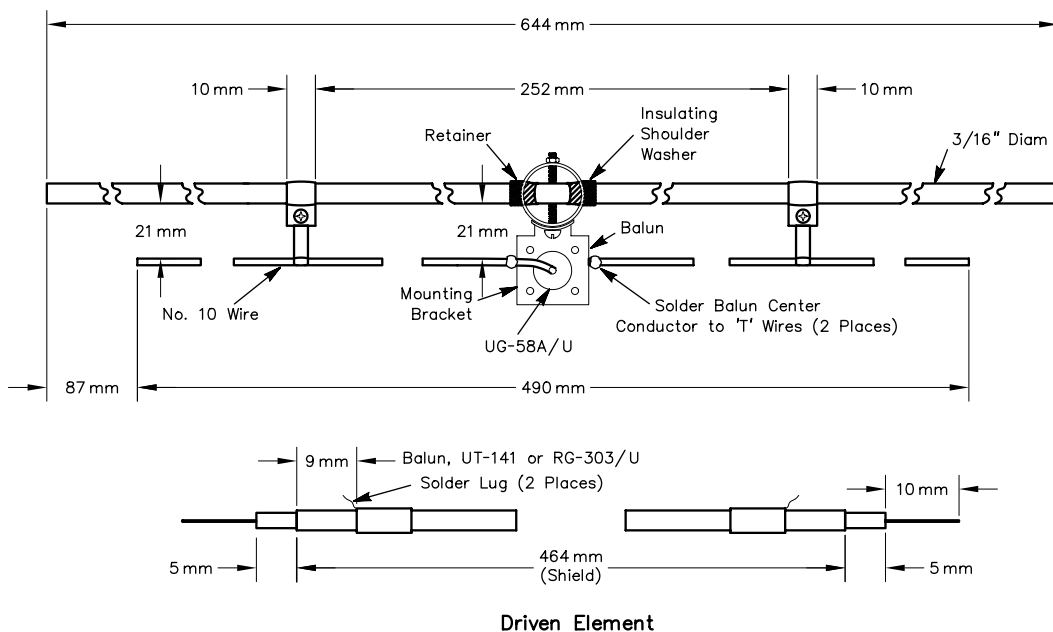

Fig 53—Driven-element detail for the 16-element 222-MHz Yagi. Lengths are given in millimeters to allow precise duplication.